

THIS DOCUMENT CONTAINS DATA PROPRIETARY TO PROJECTS UNLIMITED, INC. ANY USE OR REPRODUCTION, IN ANY FORM, WITHOUT PRIOR WRITTEN PERMISSION OF PROJECTS UNLIMITED, INC. IS PROHIBITED.  
© 2005, Projects Unlimited Inc.

### SPECIFICATIONS

| PARAMETERS  | VALUES     | UNITS |
|---|------------|-------|
| RATED INPUT POWER                                 | 1.5        | W     |
| MAX INPUT POWER                                   | 3          | W     |
| IMPEDANCE   | 8±15%      | OHM   |
| OUTPUT SPL @ 1W/1M<br>(AT 1.0, 1.2, 1.5, 2.0 kHz) | 85±3       | dBA   |
| DISTORTION (MAX.)                                 | 5%         | -     |
| RESONANT FREQUENCY                                | 800±20%    | Hz    |
| FREQUENCY RANGE                                   | 800 ~ 7000 | Hz    |
| HOUSING MATERIAL                                  | METAL      | -     |
| CONE MATERIAL                                     | MYLAR      | -     |
| MAGNET MATERIAL                                   | N35        | -     |
| OPERATING TEMPERATURE                             | -25 ~ +60  | °C    |
| WEIGHT  | 17.6       | grams |

| REVISIONS |                           |          |          |
|-----------|---------------------------|----------|----------|
| LTR       | DESCRIPTION               | DATE     | APPROVED |
| -         | RELEASED FROM ENGINEERING | 10/10/06 |          |

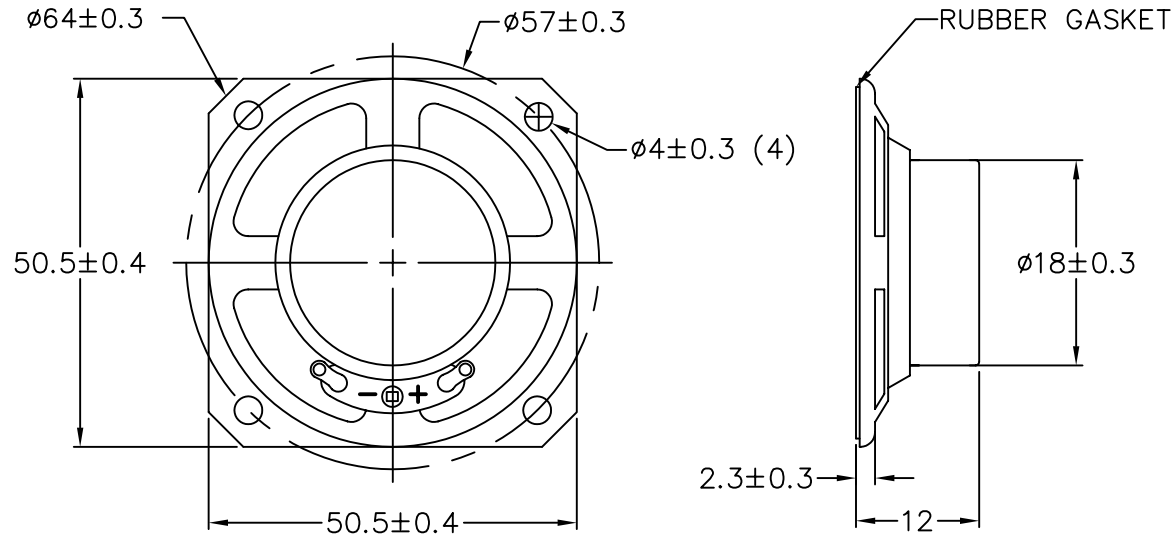

**NOTES:**

- ALL DIMENSIONS ARE IN MILLIMETERS.
- SPECIFICATION SUBJECT TO CHANGE OR WITHDRAWAL WITHOUT NOTICE.
- THIS PART IS RoHS 2002/95/EC COMPLIANT.

FILE NAME  
AS05008MS-R.DWG

|   |      |  |                            |
|---|------|--|----------------------------|
| UNLESS OTHERWISE SPECIFIED:<br>DIMENSIONS ARE IN MILLIMETERS, TOLERANCES ARE $\pm 0.5$ AND ANGLES ARE $\pm 3^\circ$ . |      |  <b>projects® unlimited</b><br>Dayton, Ohio |                            |
| APPROVALS   |      | DATE   |                            |
| DRAWN   | J.D. | 10/06  |                            |
| CHECKED   | B.R. | 10/06  |                            |
| APPROVED  | R.W. | 10/06  |                            |
| DO NOT SCALE DRAWING  |      | SIZE<br>A  | DRAWING NO.<br>AS05008MS-R |
|   |      | SCALE: N.T.S.  | SHEET 1 OF 1               |

# SPEAKER